

OPTICAL DATA TRANSMISSION DEVICE FOR SafetyBUS p

BWF-1S



***General**

This device provides the function of optical repeater and makes a wireless communication between master and slave or master's under SafetyBUS p.

***System construction**

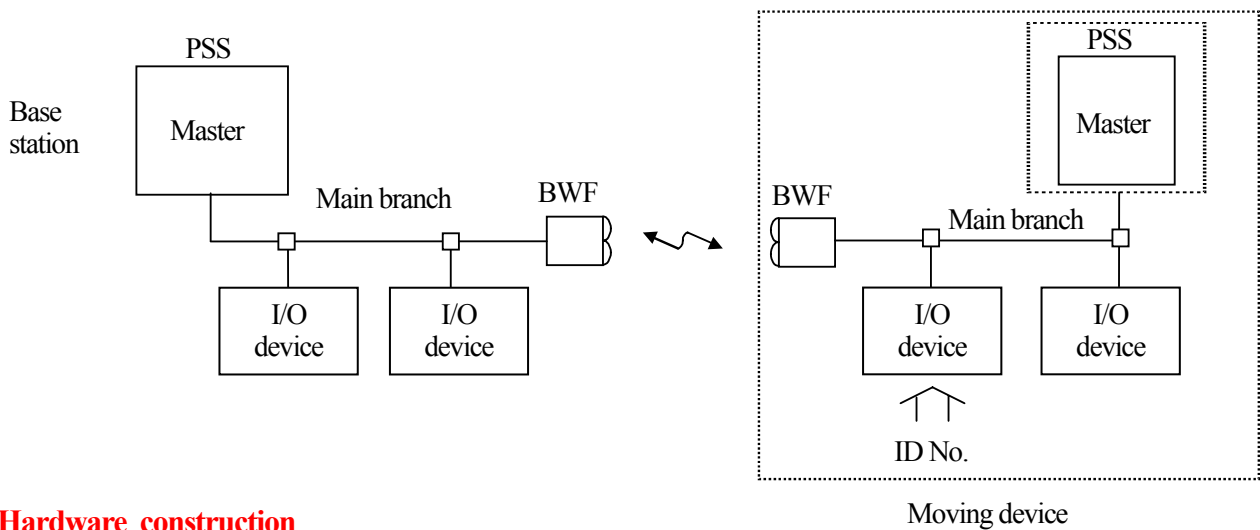

***Hardware construction**

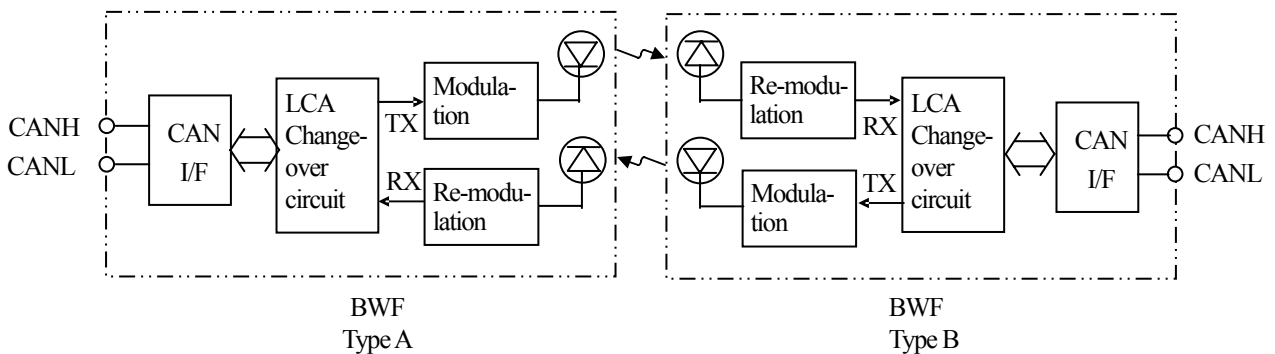

* Make sure to use with one pair of type A and type B.

* Specifications

Model No.	BWF-1SA	BWF-1SB	
Power source	24VDC(+/- 15%)		
Current consumption	Max. 130mA(Input voltage 24VDC)		
Transmission delay	500nsec		
Optical transmission part	Transmission distance	0 to 70m	
	Directional angle	50m or less : Full angle 2 degrees, 50m or more : Full angle 1 degree	
	Transmission system	Full-duplex two-way transmission device	
	Modulation system	FSK	
	Modulated frequency	35M +/- 3MHz	45M +/- 3MHz
	Transmission speed	0 to 500kbps	
Network	Connection type	Multi-drop system	
	Communication speed	Max. 250kbps	
	Communication media	Exclusive cable 5 wires(Signal 2 wires, power 2 wires, shield 1 wire)	
	Transmission distance	Transmission speed	Max. network length
		250kbps	100m or less
125kbps	350m or less		
Ambient illuminance	10,000lux		
Ambient temperature/humidity	-10 degrees to +50 degrees C, 10 to 85%RH or less(Not dew-drop)		
Ambient temperature when stored	-20 degrees to +75 degrees C		
Vibration resistance	Double amplitude 1.5mm, 10 to 55Hz, each 2 hour in X, Y and Z directions		
Impact resistance	490m/s ² each 10 time in X, Y and Z directions		
Protective structure	IP40		

* External dimension

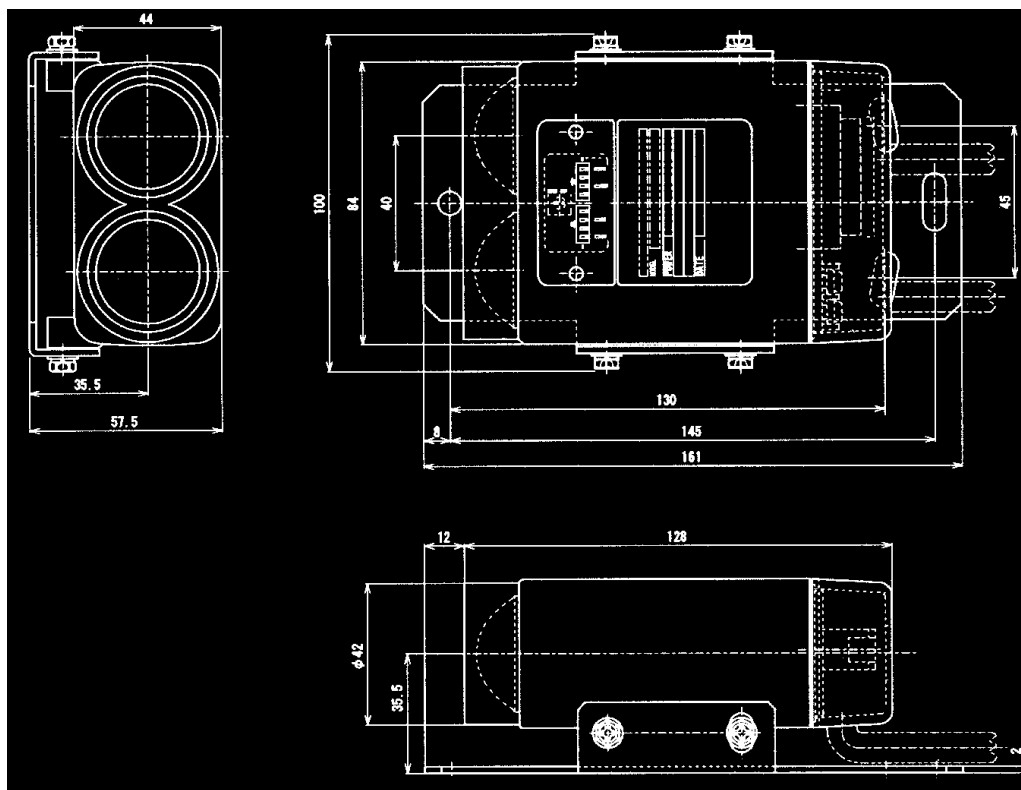

Europe's Official HOKUYO Distributor

1010 Cambourne Business Park, Cambridge, CB23 6DP UK.

Tel +44 (1223) 923 930 : Fax +44 (1223) 923 940
info@sentekeurope.com : www.sentekeurope.com